

TYPHON

TERROR X2 Mini Excavator

Use and Maintenance Instructions

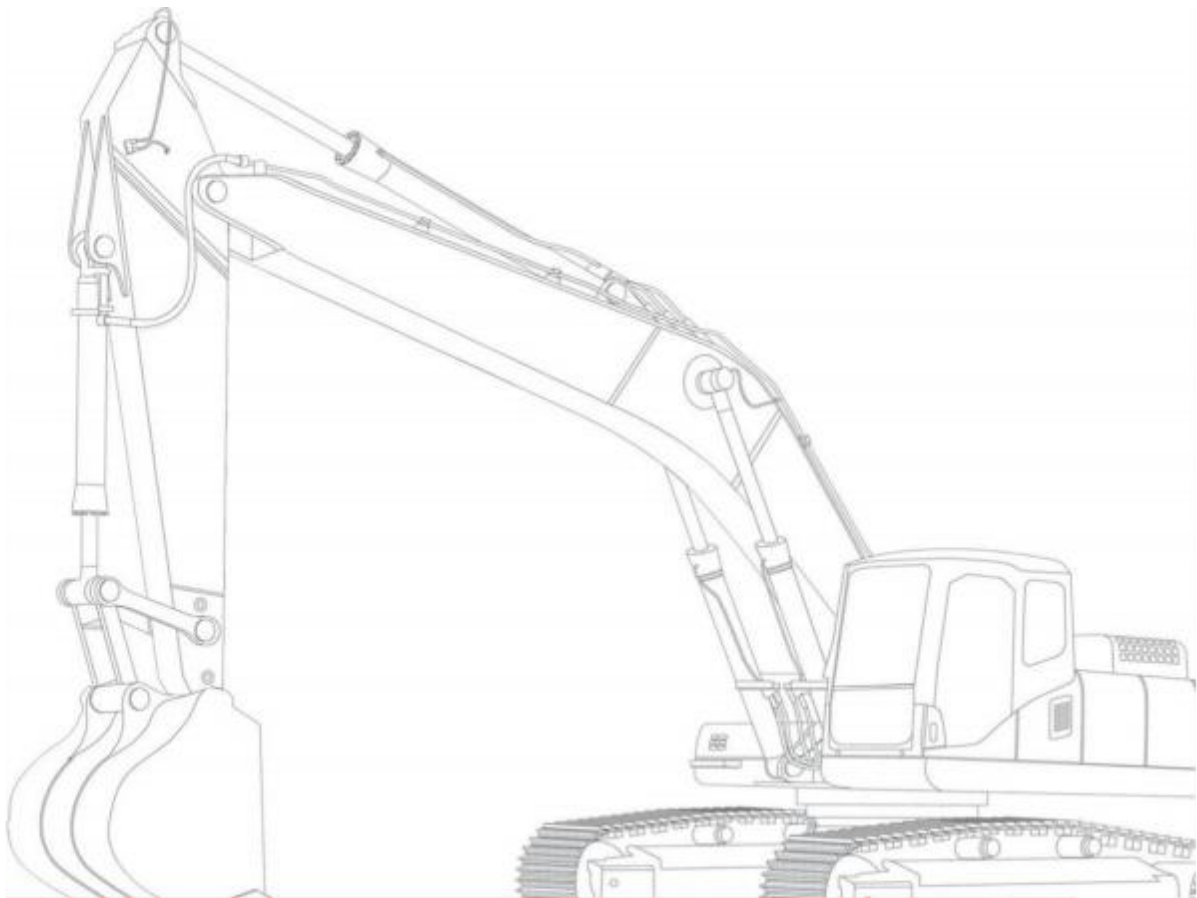

Foreword

Dear users:

Thank you for your trust and love for our products! The compact excavator manufactured by TYPHON Machinery is a small excavator with excavation operation as a main work as well as lifting, loading and unloading operation work as an auxiliary work. The excavator has a compact design structure, proper power matching, good product stability and high performance cost ratio, which can meet the requirements of the excavation and loading unloading under different working conditions such as plains, hills and forest areas. It is also suitable for dredging and road construction in brick and tile factories, kiln factories, river courses, buildings, and the most ideal construction machinery for farmland operation and small project.

In order to enable user to correctly understand the knowledge on use, adjustment, repair and maintenance of this excavator and give a full play to the function of excavator, please read this *Use and Maintenance Instructions* carefully and implement the provisions in this *Use and Maintenance Instructions* before you use this compact excavator. For the use and maintenance of the matching engine, please refer to the *Engine Operation Manual* prepared by the matching engine factory.

The content for use and operation is the technical reference for the driver to use this excavator, and the use and maintenance instructions will guide driver to use the correct procedure for checking, starting, operating and stopping this compact excavator in a form of the graphic comparison. The operation technology outlined in this Instruction is a basis. As long as the drivers acquire knowledge of the excavator and its functions, they can improve their skills and skills.

The contents for the maintenance of this excavator are guidelines on user's maintenance and repair of this excavator. The illustrations are arranged in descending order according to the maintenance period. The specific maintenance measures for the excavator are detailed in *the Periodic Table of Lubrication and Maintenance*. Users should maintain the excavator according to the requirements of *the Periodic Table of Lubrication and Maintenance* and different mechanical working hours.

An appropriate frequency of lubrication of the excavator should be increased under the extremely harsh, dusty, or humid working conditions according to the operation status of the excavator.

In order to show some structural features of the excavator more visually, some demonstration images in the Use and Maintenance Instructions are set to the structural perspective and there are some differences on the appearance of the actual product. Due to changes of the actual mechanical structure and technical parameters of the excavator caused by the technical improvement, if the

product information is not provided in the Use and Maintenance Instructions, please contact our company for the latest production information.

Before this excavator is used and maintained, users should check and verify the relevant data information on the excavator, if necessary, and contact the technical service station of the Company. When users purchase parts, the date of manufacture and serial number of excavator should be stated. In order to facilitate users' use of the excavator, the Company has established a perfect after-sales service system, and user can contact the Company's after-sales service specialist for consultation at anytime in the process of use and maintenance of the excavator.

Table of Content

Safety precautions	1-4
Precautions on preparation of excavator.....	5
Precautions on starting of excavator	5-6
Schematic diagram for safety signs	7-11
Precautions on operation of excavator.....	12-18
Precautions on traction of excavator.....	19-20
Hydraulic crushing hammer.....	2 1 - 2 3
Precautions on stopping run of excavator	24
Precautions on transportation of excavator.....	25
Precautions on maintenance of excavator.....	26
Precautions on regular inspection and maintenance of excavator.....	27-28

Safety precautions

It is your responsibility to comply with the safety specification and laws of the relevant authorities, and operate, inspect and maintain the excavator as required by the manufacturer.

In fact, all accidents are caused by non-compliance with basic safety specifications and precautions. Most accidents can be avoided by identifying potential hazardous conditions in advance.

Please read and understand all safety information on how to prevent accidents. Please do not operate this excavator until you are sure that you know about technologies on how to operate, check and maintain it correctly.

Compliance of all safety specifications: the excavator must be operated, checked and maintained by trained and qualified personnel; such trained and qualified personnel should understand and comply with all rules, specifications, precautions and safety measures during the operation, checking and maintenance of the excavator and they should not operate, check and maintain this excavator under the conditions of adverse effects caused by alcohol, drugs, medicine and fatigue or lack of sleep.

Occurrence of failure on this excavator: if the user finds that, during the operation, checking and maintenance of the excavator, such failure (for example, noise, vibration, peculiar smell, oil leakage and false alarm, etc.) occurs on this excavator, user should immediately stop running the excavator and shut down it. Please do not operate the excavator until its failure has been eliminated.

Range of operating temperature of excavator: In order to maintain the performance of the excavator and prevent from premature wearing of the excavator, please user observe the following operation conditions: If the outdoor temperature is above +45°C or below -15°C, please do not operate this excavator; if the excavator is operated under the condition of the outdoor temperature above +45°C, its engine may be overheated to result in the decrease of the engine oil performance.

In addition, the temperature of the hydraulic oil may rise to result in the damage to the hydraulic equipment. If the excavator is operated under the condition of outdoor temperature below -15°C, rubber parts such as gaskets in the excavator may be hardened to result in the premature wearing or damage to the excavator. If users need to operate the excavator outside the range of the above outdoor operation temperature, please consult the sales or after-sales service personnel and wear appropriate clothes and protective equipment (as shown in the figure).



Please do not wear loose clothing or decorative items that may be attached to a controlling lever. Do not collide with the operating handle and result in its operation, and avoid collision with other objects.

According to the requirements of working environment, wear safety shoes, safety helmet, safety glasses, filter mask, gloves, ear protection and other protective equipment.

Before operating the excavator, the operator should walk around the excavator to check whether there are people or obstacles around it.

Installation of fire extinguisher

Do a good job for fire or accident and knowhow to use fire extinguisher correctly.

Do not remove safety equipment: please make sure that all protective guards are installed in place and firmly. Before operating the excavator, please check that the safety equipment is firm.



The safety lock should be closed when the operation of the excavator is finished or stopped. The starting key should be pulled out after the work is finished.

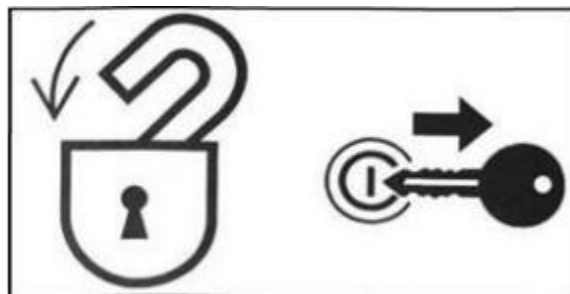

Avoid breaking out of fire and explosion hazards



Do not smoke or have open fires while working on fuel or fuel systems. It is forbidden to carry fire source, inflammable and explosive materials.

Do not leave the work site when replenishing fuel or lubricating oil. Do not remove the tank cap or add oil when the engine is running or has not cooled down. In addition, do not splash fuel onto the hot surface of the excavator or components of the electronic system.

Before operation of the excavator, if finding oil stains on the surface of the excavator, please check whether there is oil leakage in the excavator. After confirming that there is no oil leakage, wipe it clean before starting the excavator.

A short circuit in the electronic system may cause a fire. Regularly check whether the wire connection is loose or damaged. Re-tighten the loose connectors and cable clips. Repair or replace the damaged wires.

Pipeline oil-way: Regularly check the pipeline oil-way. Make sure that the clips, protective equipment and cushion rubber are fixed firmly. If the hose or pipe is loose, they will be damaged during operation due to vibration or contact with other parts. It may cause the leakage of the high pressure oil to result in fire or injury to human body.

Protection against Harmful Gases



Caution harmful gas poisoning

When working in a poorly ventilated or sealed environment. Pay attention to wear a protective mask and install the air-exhausting device. Be sure to wear a dust mask when working in the environment with more dust. Avoid working in the environment with more dust for a long time, which will cause harm to the human body.

Be careful not to squeeze



Do not place your hands, feet or other body parts between the tracks. When the excavator is in the state of starting operation, it is strictly prohibited to stand other people within the operating radius and pile up objects that obstruct the operation of the excavator. Avoid causing bruising and crowding.

Precautions on preparation of excavator before operation:

Understand the operating environment: Before starting the operation of the excavator, you should understand the operating area to ensure safety.

Check the terrain and ground conditions of the operation area, and check the structure of the building while carrying out operation indoors, and take safety measures if necessary. Be sure to avoid hazards and obstacles in areas such as gutters, underground pipelines, trees, cliffs, overhead power lines, or falling rocks and landslides.



Precautions on starting of excavator:

Before operating the excavator, walk around it to make sure that there are no other workers or obstructions within the rotation radius of the excavator.

Climb on/off the pedals facing the excavator and hold on to the handrail to support your weight in three safe positions (hands and feet). Do not pull control lever.

Check whether there is a warning Label or similar Label with “Do Not Operate it” on the driver’s cab, braking or starting switch. If so, please do not start the engine or touch any joystick

Contact relevant personnel to confirm whether the excavator is available. When there is no mistake, buckle up seat belt. Honk the horn to warn people around the excavator. Make sure that the operating arms are in the middle position to start it.



After starting the engine, operate the excavator in areas where there are no people or obstacles. If any fault is found, press the program to shut down it and report the fault.

- Preheat the starter and hydraulic fluids.
- Check whether all instruments and alarm are working properly.
- Check whether there is noise.
- Test rotational speed control of engine.
- Operate the controls to ensure they work properly.



Warning
Fasten your seat belt
before starting the
excavator

Use in cold climates



Pay attention to ground freezing in cold weather; the surface of pedals and handles is very smooth.

Do not touch any metal parts of the excavator with bare hands in cold weather. The skin can be frozen onto the metal, thus causing serious damage.

Do not use ether or starting fluid for the engine. Starting fluid can cause explosions and serious injury or death.

Preheat the engine and hydraulic fluids. In cold weather conditions, the excavator will idle for 2 to 5 minutes after starting. If the control lever is operated without preheating, the excavator will not make a reaction or movement quickly or appropriately, thus causing an accident.

Schematic diagram of safety Labels:

1. Schematic diagram for operation of working equipment

▲ Check whether the excavator control mode is consistent with that on the label. If not, replace the label before operating the excavator to match the excavator control mode.

▲ Failure to do so may result in casualties.

Mechanical operating system (forehand)

Warning

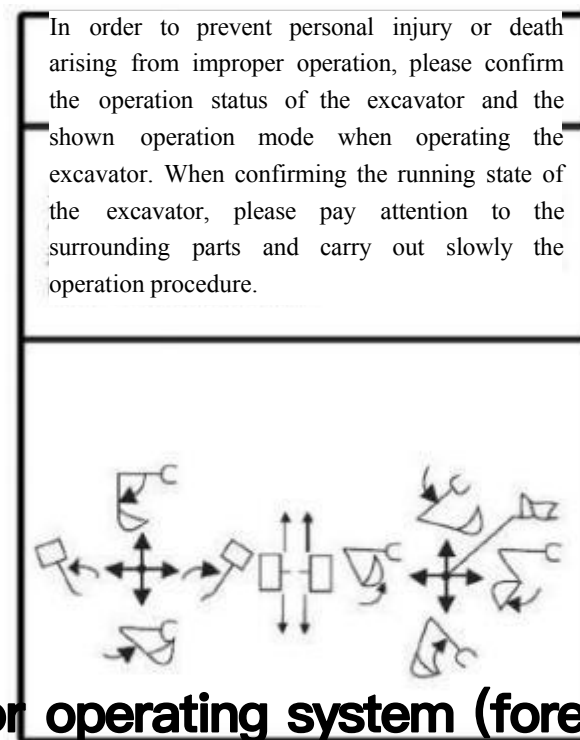

Precursor operating system (forehand)

Composite action

Turn left and open forearm	Stretch out of forearm	Turn right and open forearm
Rotate to the left	Left	Rotate to the right
Turn left and close forearm	Take back forearm	Turn right and take back forearm

Take back bucket and drop movable arm	Drop movable arm	Start bucket and drop movable arm
Bucket digging	Right	Bucket uninstillation
Take back bucket and lift movable arm	Lift movable arm	Star bucket and lift movable arm

2. Precautions for adjusting the tenseness of the caterpillar band: This label is located on both sides of the beam of caterpillar band.

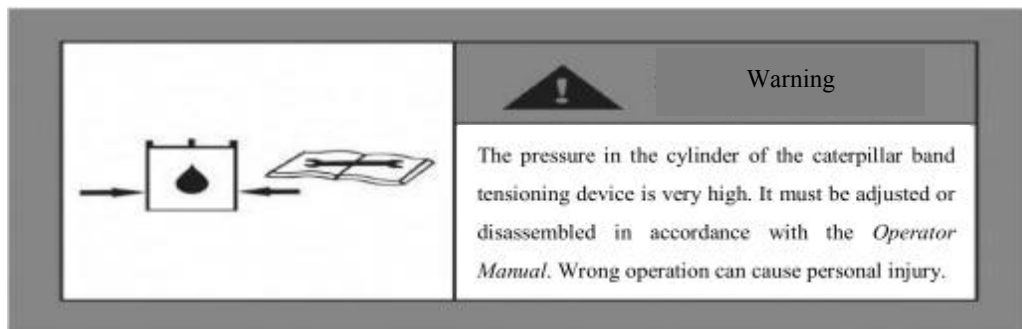

3. Warning Labels such as operation warning, loading warning, movement and operation warning, opening front window warning, pay attention to high-voltage cable, reading instructions, oil-way lock and height. These labels are located in the lower right side of cab.

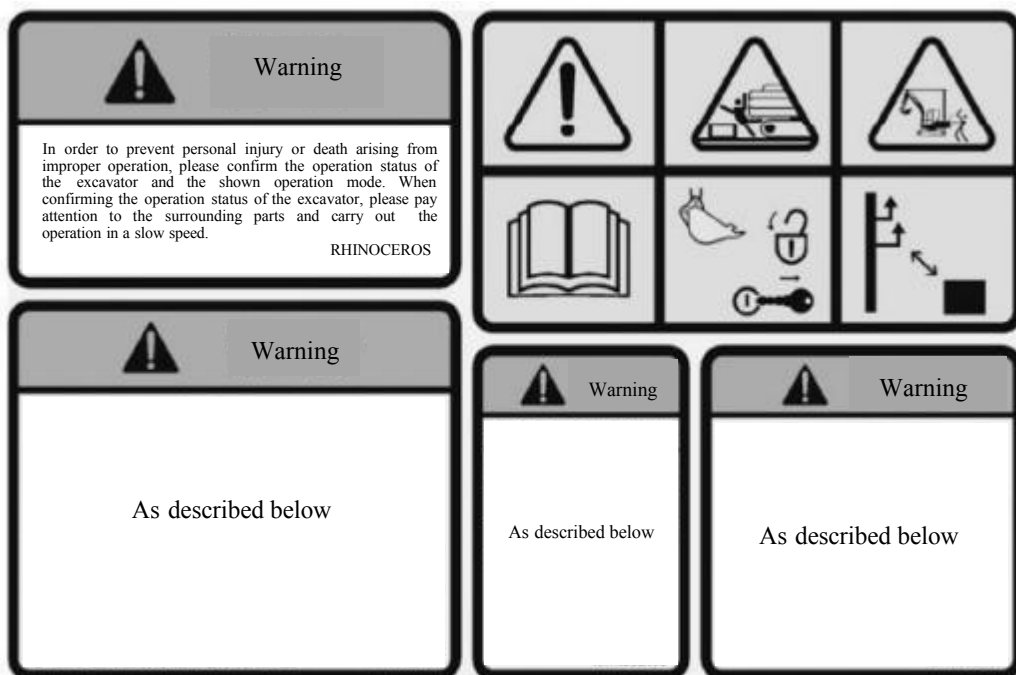

For the purpose of safety in loading and unloading operations to (from) transport vehicles, the following matters shall be strictly observed.

- The transporter's brakes must work and the tires should be plugged with a gear block.
- Loading and unloading plates shall be made of steel plates with great length, width, strength and non-sliding surface.
- In order to align the transporter with the excavator center, the loading and unloading plates are properly fixed.
- A cushion block or support must be placed under the loading plate.

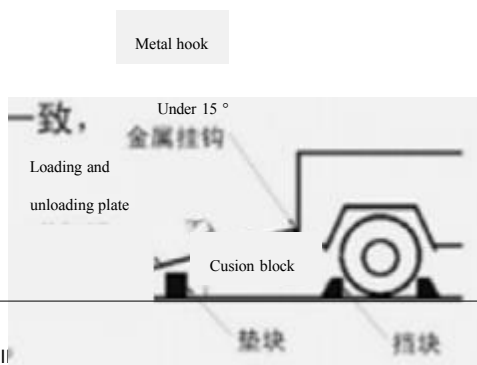

- The Angle of the loading and unloading plate is below 15 degrees.
- Loading and unloading operations should be carried out in flat and rugged areas.

RHINOCEROS

To prevent serious injury or death, please comply with the following matters before moving the or operating the excavator.

- Please honk your horn to inform those around you.
- Please make sure that there are no people above, around or in the rotating area of the excavator.
- To ensure a wide view in the direction that the excavator moves forward, please rotate the upper part of the excavator, if necessary.
- Please appoint a monitor in areas with a poor field of view.

For the above-mentioned matters, please abide by the driving warning and install the reflector.

RHINOCEROS

- If opening or closing the front window or removing the window, turn the safety lock lever to the lock position before the driver stands up from the driver's seat.
- If touching the operation lever carelessly, the excavator will move suddenly, which may cause serious personal accident.

RHINOCEROS

4. Label far away from the turning area: This label is located on the rear counterweight.

- ▲ People are strictly prohibited to stand within the turning area of the excavator.
- ▲ Do not damage or remove the logo from the excavator.



5. Diesel oil label: This label is located on the diesel oil tank.

- ▲ Engine should be turned off at the time of filling diesel oil. Diesel oil should be away from all open fires at the time of filling.

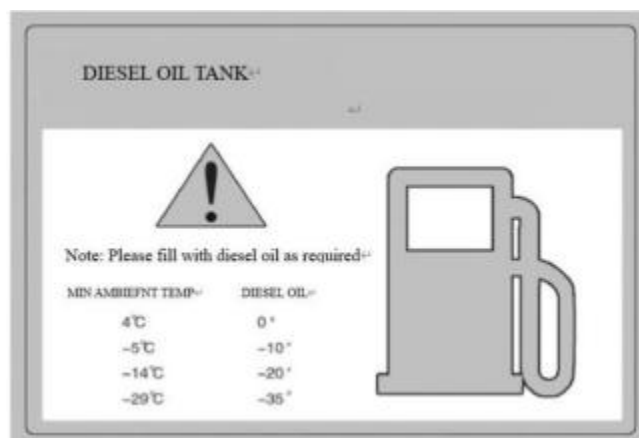

6. Matters needing attention on diesel oil

 **Attention**

Diesel oil tank

Do not smoke when filling with diesel oil or maintaining the fuel system for the excavator. No refueling or maintenance for the excavator is allowed near the flame or cremation area. The engine must be stopped before refueling. Fuel for the excavator outdoors

7. Precaution for use of battery

 **Danger**

The battery can produce explosive gas, and should be away from fire source and open flame. When the battery is used, it is ensured that the battery should be stored in a place with good ventilation.

Do not place metal objects such as tools or flammable objects with the battery. Waste batteries should be disposed according to local environmental laws and regulations.

The electrolyte in the battery is highly corrosive, which can corrode the skin and clothes. If it is splashed in the eyes, it will lead to blindness. If sulfuric acid is spilled on the human body for the reason of carelessness, you should:

1. Rinse the skin with water.
2. Neutralize the acid with soda or lime.
3. Rinse eyes with water for 10-15 minutes and receive treatment immediately.

8. Hydraulic oil label: This label is located on the hydraulic oil tank.

HYDRAULIC OIL TANK[Ⓔ]

Note: Please fill the hydraulic oil as required

Summer: YB-N46 anti-wear hydraulic oil[Ⓔ]

Winter: YC-N46 low temperature hydraulic oil[Ⓔ]



9. Electric shock hazard label

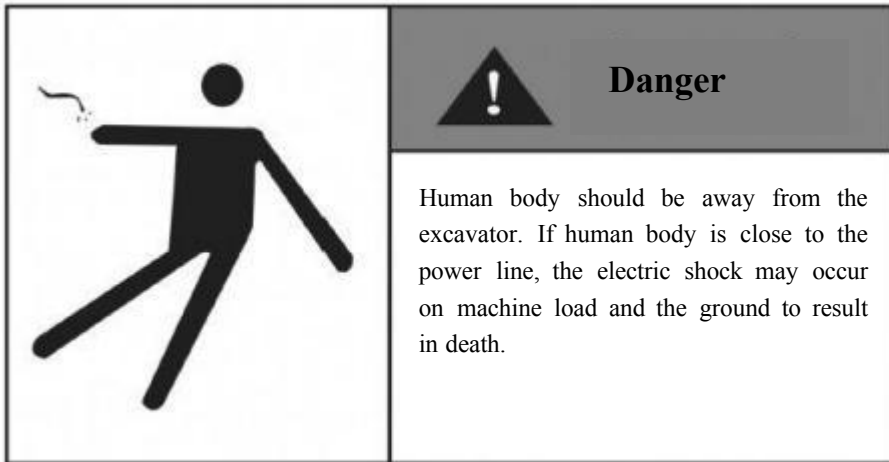

10. Anti-skid warning label

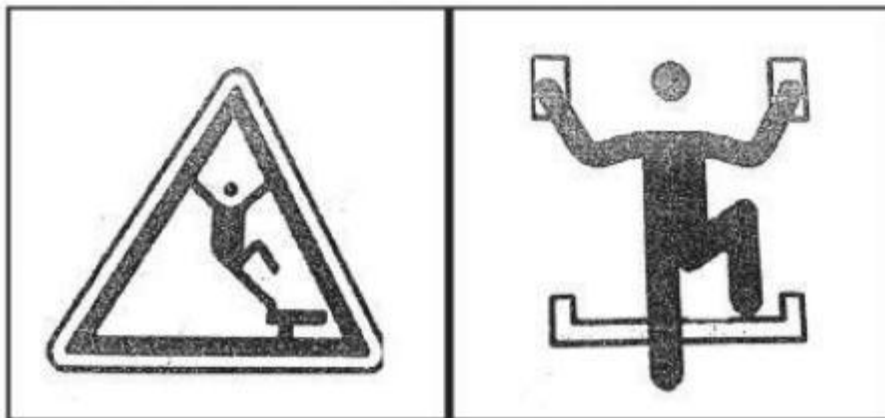

11. Please be away from the dangerous area



Precautions during operation of excavator:

It is ensured that good visibility is provided: When working in dark areas, turn on the working lights and headlights of the excavator, and install additional lighting if necessary.



When line of sight is poor due to severe weather (for example, fog, snow, rain or haze), the excavator should not be operated until line of sight improves.

Do not carry people on the excavator: No one shall be allowed to ride on any part of the excavator at anytime while the excavator is being moved or operated.

Verify performance limits of the excavator. The excavator should not engage in work beyond the working scope, which may easily cause harm to persons or objects.

Use a signal source on the shoulder, narrow place and place where line of sight is obstructed.

Do not allow anyone to enter into the turning radius and path of the excavator.

Express your intention to move the excavator by honking horn. There is a blind area behind the excavator. Before moving backwards, please check the rear safety and make sure that there is no one in its rear.

Before operating the walking joystick/pedal, please make sure that the walking joystick/pedal is in the front of the driver's seat. It is remembered that, when the dozer blade is behind the driver's seat, the operation direction of the walking joystick/pedal must be in the opposite direction from the dozer blade in front of the driver's seat.

Safe walking:

The dozer blade is lifted at the time of moving

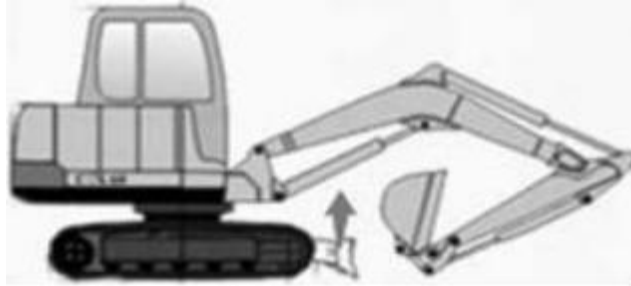

Avoid crossing over obstacles as possible as. If this must be done, keep the bucket operating unit to be close to the ground and move slowly. Do not cross over obstacles that will tilt the excavator at an angle of 10° or more.

Keep moving at a low speed on uneven roads to avoid sudden starting, stopping or changing direction. Otherwise, the working equipment may come into contact with the ground to cause the excavator to lose balance and damage or break its structure in the surrounding area.

Precautions for moving on slope

When the excavator moves on a slope or ramp, it should be noted that the machine should not capsize and slide down.

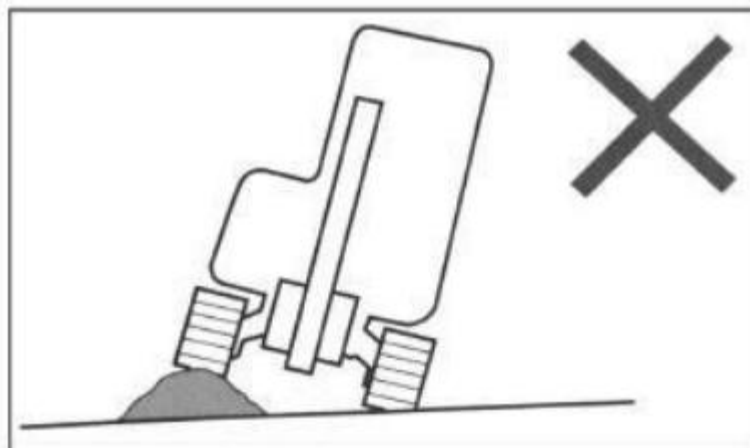

Do not move on too steep slopes (maximum gradient: 30°, lateral inclination: 10°) where the stability of the excavator cannot be maintained. Note that, in fact, the stability of the excavator may be lower than above value, which depends on the working conditions.

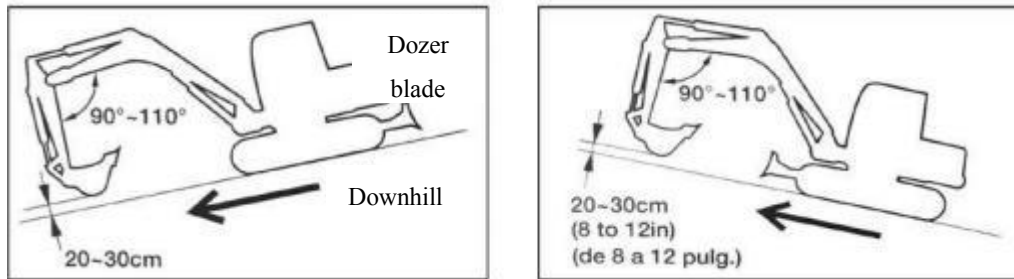

When climbing, keep the driver's seat to face the hill. When going down, keep the driver's seat to face down the hill. In both cases, you must pay attention to the ground in front of the excavator.

Lower the bucket 20 to 30 cm above the ground when moving on a slope. When climbing a steep hill, extend the bucket operation device to its front. In an emergency, drop the bucket to the ground and turn off the excavator.

Drive slowly at a low speed while moving on a slope or ramp. Reduce engine speed as the excavator descends the ramp.

Do not reverse downhill.

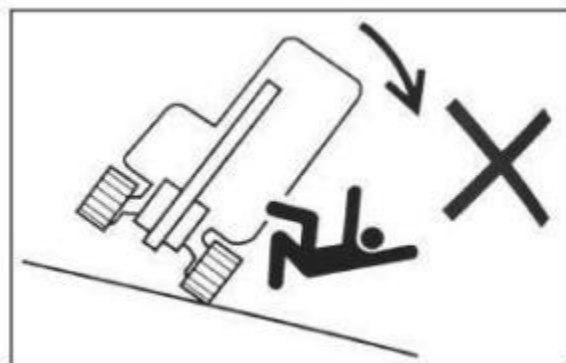

Do not change direction on slope or cross slope. First return back to the flat surface, then select another path.

On gentle slopes covered with grass or dead leaves, or on wet metal plates or frozen ground, the excavator may slide sideways. It is ensured that the excavator is not parked horizontally on the slope.

If the excavator is stalled on a ramp, return each joystick to its neutral position and restart the engine. Pay additional attention to the excavator when operating excavator on snow or ice

When moving on snow or frozen ground, drive it at a low speed to avoid sudden start, stop or change of direction.

When the excavator is parked on unstable ground, the dozer blade should be lowered.

Please do not move the bucket above the head of the personnel. If the bucket is moved above the head of the personnel, the loads will scatter or the bucket will drop suddenly (As shown in the figure below).

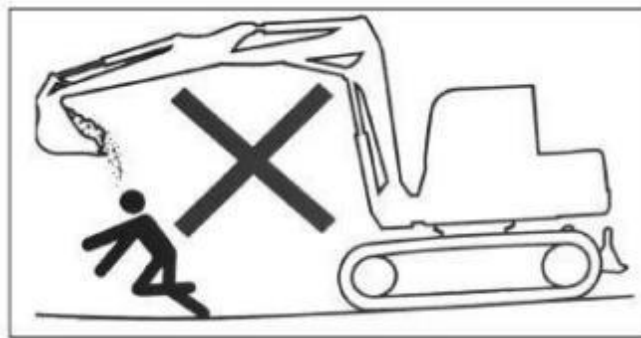

It is ensured that driver is in a safe position at the time of loading cargoes

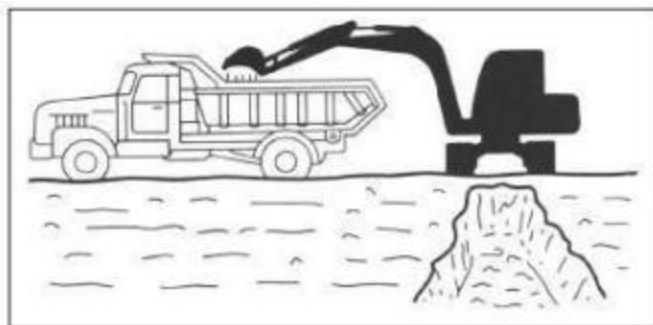

Keep a safe distance from the high voltage cable during driving or working of the excavator



High voltage cables buried in the ground (see figure below). Check it with relevant personnel before construction to confirm whether there is any underground cable at the construction site.

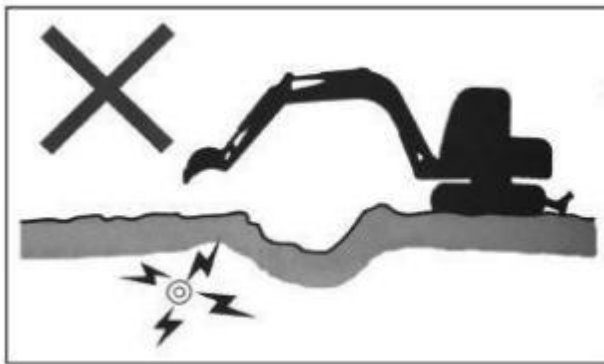

Do not operate the excavator in an environment where there is a danger of collapse or falling rocks, and take appropriate protection measures for the excavator.

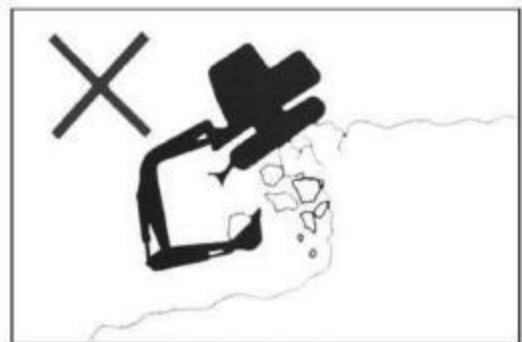
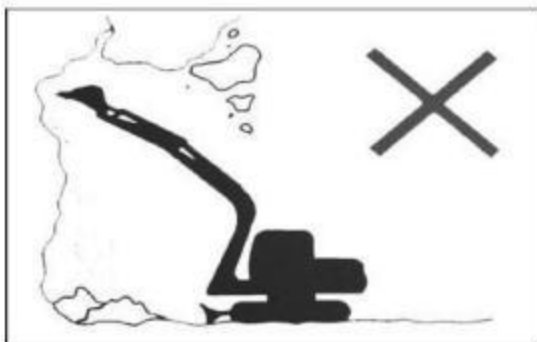

Do not carry out dismantling operation by means of impact force of the bucket device, and it is easy to result to the damage on the bucket device and rotary device.

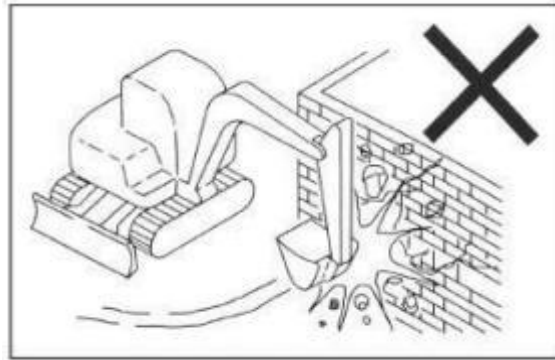

When operating the excavator on a slope or ramp, turning or operating a working device may make the excavator unstable and overturned. Operation of the excavator on slopes should be avoided as far as possible.

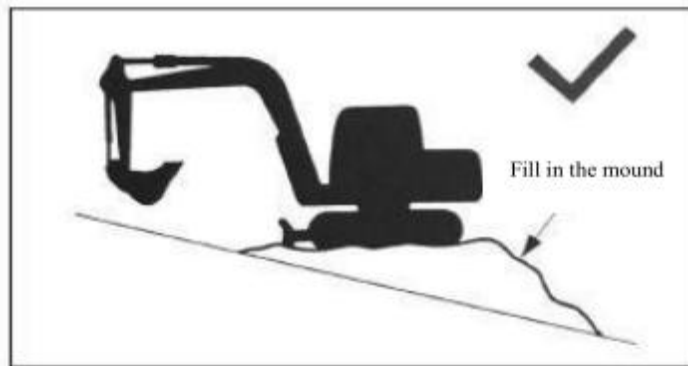

When operating the excavator on a slope or ramp, turning or operating a working device may make excavator unstable and overturned. Operation of the excavator on slopes should be avoided as far as possible.

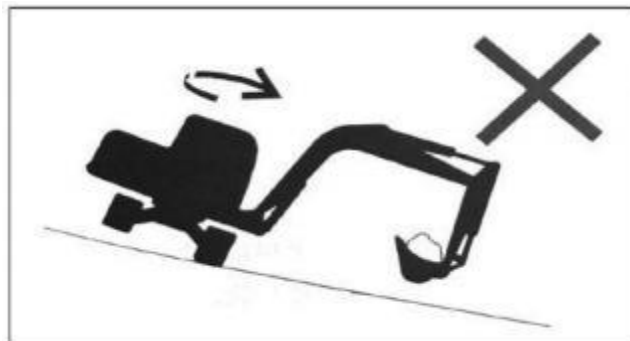

When the excavator is running or working, operator should pay attention to the height of the top of the excavator in the construction environment.

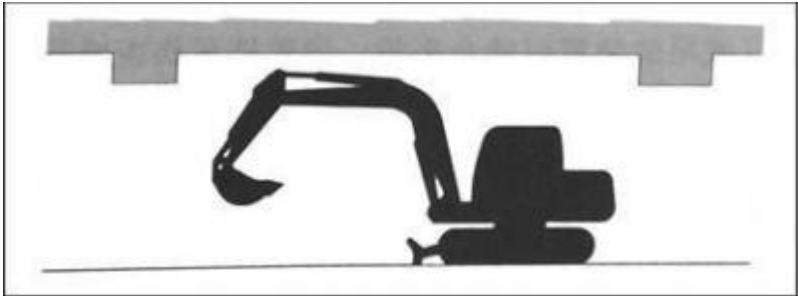

Do not overload hoisting, overlong. Overloading can cause excavator to capsize and result in serious injury or death.



Precautions during traction:

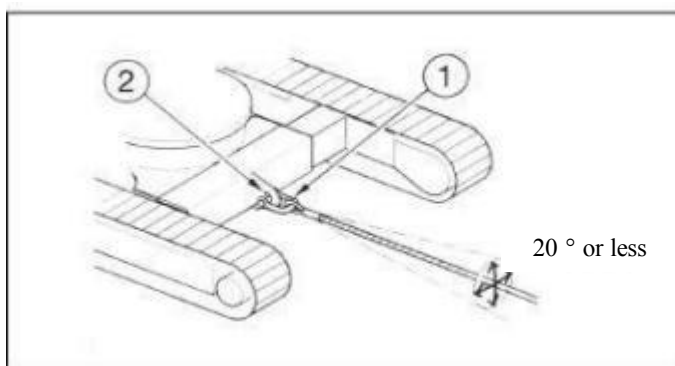

Improper handling, use of the wrong cable, or improper inspection during traction can result in serious injury or death.

If the cable breaks or falls off, there will be a danger to operator. Use the wire rope that matches the traction force. Do not use twisted, twisted or even damaged cables. Do not suddenly apply heavy load on the cable; Wear safety gloves when handling cables.

It is ensured that there is one operator on the excavator being towed or to be towed. Do not pull the cable on slopes.

No person shall approach the cable during traction.

Excavation

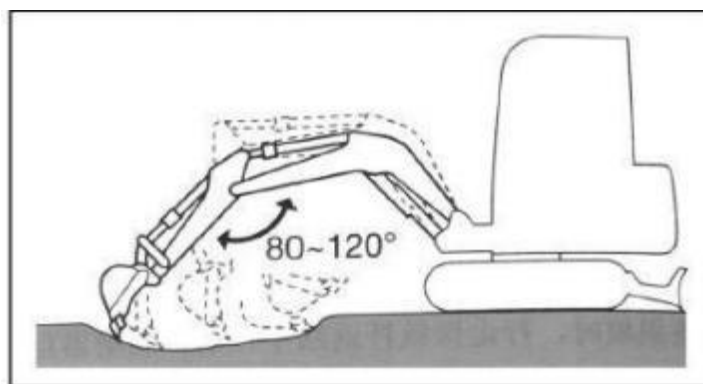

1. Carry out excavation work with the bucket rod and bucket. Excavation depth should be shallow, and travel should be long. When the angle between the movable arm and bucket rod is from 80° to 120°, the digging force reaches its maximum. The effective excavation should be carried out by using this angle.

Digging ditches

Install a bucket suitable for digging ditches and adjust caterpillar band to a proper position parallel to the ditches to be dug.

When digging a wide ditch, dig its sides first, then the middle position.

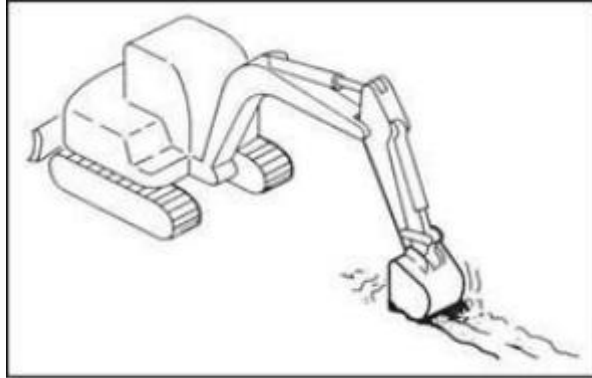

Leveling

1. Enable the bucket working device to be close to the excavator body.
2. Slowly push the soil away from the side of the soil mound.
3. When the soil mound is low, push soil from the top. If the load is too heavy for the excavator body, raise or lower the dozer blade to adjust it to a proper position.

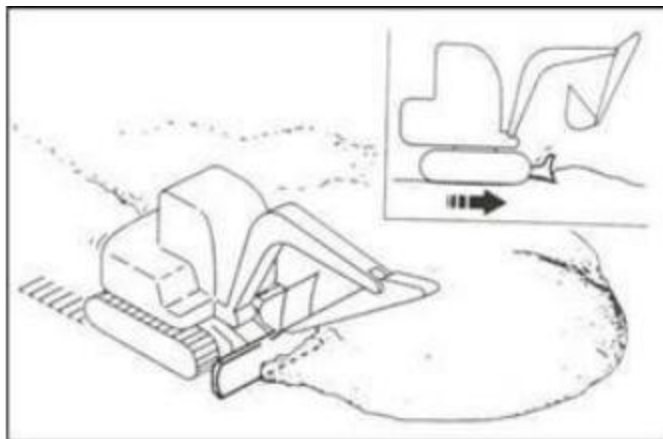

Treatment of rubber tracks:

Due to the use of rubber, rubber tracks have an inherent weakness, namely lack of strength. Please observe the following prohibitions and precautions to prevent the track from being damaged or falling off.

Ban

Do not move or operate the excavator in the following places: for example, gravel, extremely rough hard rock, steel beams, scrap iron; If the excavator is close to the edge of the steel plate, which will damage the rubber belt tracks.



Moving excavator on a riverbed or in a place with a large number of pebbles may cause the stones to get stuck in the caterpillar band and damage it, or cause it to fall off.

Do not use this unit at the beach. Salt may corrode the excavator.

When operating this excavator, please observe the following precautions:



Do not use the bucket working device to rotate the underslung frame when it is raised in front of the excavator body (the excavator does not rotate). Otherwise, the caterpillar band will be twisted when the load is concentrated at a single track point, thus causing rapid damage and fall of the caterpillar band.

Avoid heavy impact on rubber caterpillar band caused by falling.

For long-term storage of rubber caterpillar band (3 months or longer), store it in a place that is not exposed to direct sunlight or rain.

Hydraulic crushing hammer

For the operation of crushing hammer, refer to the hydraulic crushing hammer manual provided separately.

When installing crushing hammer, tilting bucket or grab bucket, make sure that they are suitable for the type of excavator being used. Please contact your sales or after-sales service staff when selecting the attachment.



Crushing operation shall be carried out with the hammerhead perpendicular to the operating surface.

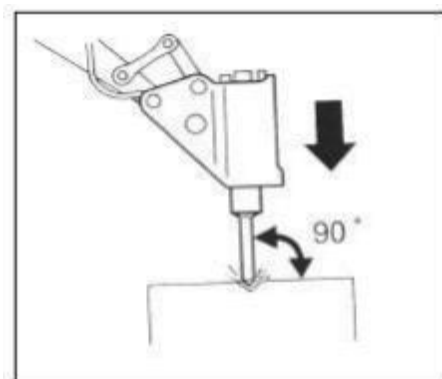

In order to avoid hitting the air, the hammerhead should be properly aimed at the object to be broken during crushing operation.

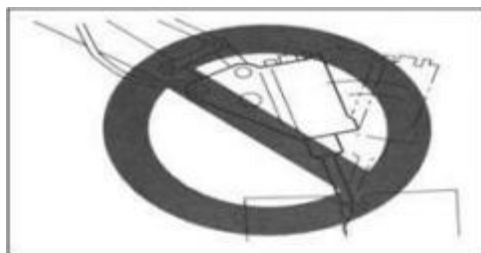

Do not pry with the hammerhead, and do not pry it at the time of crushing; Do not move the hammerhead at the time of crushing.

Do not continue to impact the same surface for more than 30 seconds.

Do not crush the cylinder when it is fully extended or contracted (the end of the journey).

Leave at least 50mm gap.

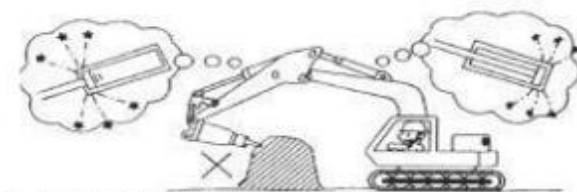

Do not crush the bucket bar when it is perpendicular to the ground

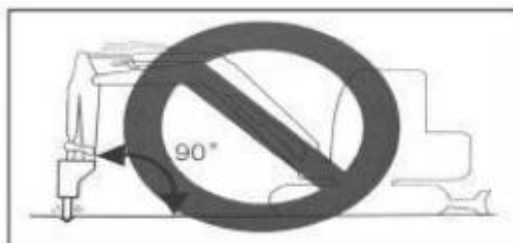

Do not crush themselves by crushing falling objects to be broken; Do not use crushing hammer to move objects or rocks to be broken.



If there is abnormal vibration in the hydraulic pipe, it maybe nitrogen leakage in the pressure reservoir. Please check it as soon as possible.

Precautions on parking:

Safe Parking



Keep the excavator on a level, firm and safe ground. Setup the parking device.

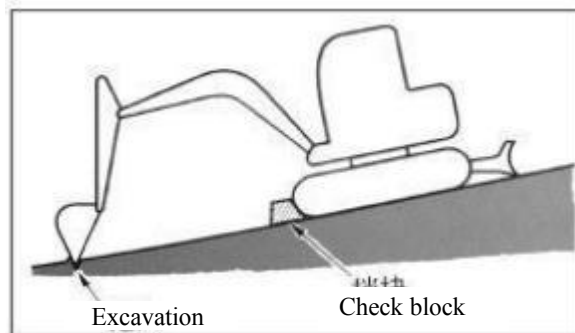

If it is necessary to park the excavator on a slope or tilt its body, the excavator should be securely parked to prevent its movement.

When the excavator is parked on the street, grilles, warning labels and lights, etc, should be used to make it easy be seen even at night and avoid collisions with other vehicles.

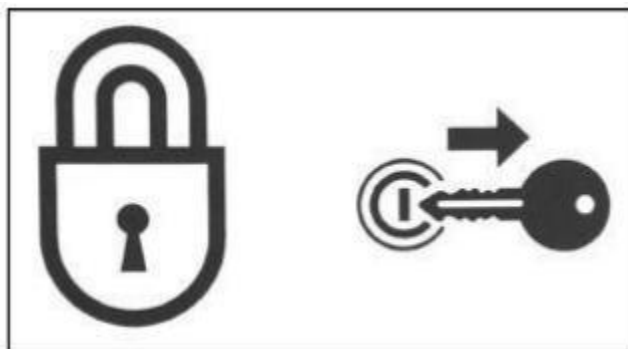

Before leaving the excavator, the following works should be done well: drop the bucket and shovel to the ground; Turn off the engine and take off the starting key. Lock the cab and take away the keys.

Precautions during transportation:

Safe loading/unloading of the excavator

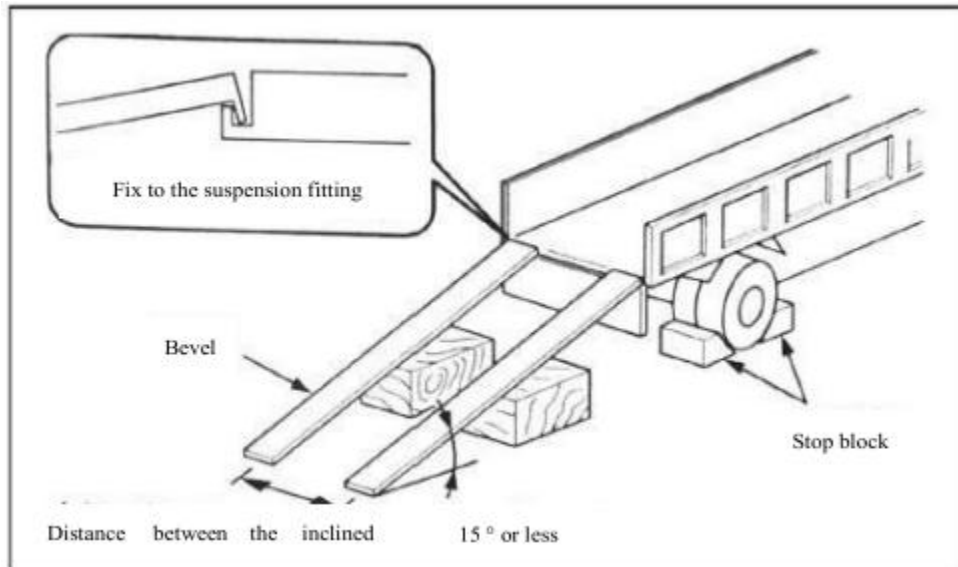

The excavator is likely to capsize or fall down during loading and unloading. Please take the following safety measures: choose a firm and flat ground and keep a sufficient distance from the road shoulder; An inclined plane with sufficient strength and size shall be fixed to the truck compartment. The slope of the inclined plane shall not exceed 15°. If the ramp bends downward too much, support it with a prop or pad.

In order to prevent the excavator from sliding sideways, keep the truck compartment and loading surface clean and free of oil, sand, ice, snow and other foreign matter. Clean the caterpillar band.

Plug the transport wheel with a wedge to prevent it from movement.

When loading and unloading the excavator, please follow the signalman's signal and move slowly in a low speed.

You must not change course on an inclined plane. Do not carry out turning/swing the excavator on the ramp. If doing so, the excavator is likely to overturn.

When turning/swinging the excavator on a truck carriage, the footing is likely to be unstable and turning/swinging operation should be carried out slowly; If possible, lock the door and lid after loading. Otherwise, it is likely to be opened during transportation. The caterpillar band is secured with a wedge, and then the excavator is secured to the truck compartment with a cable or link chain.

Safe lifting of excavator

Understand and use correct hoisting gestures.

Check hoisting equipment daily for damaged or missing parts and replace them if necessary. When hoisting, use a cable that is capable of lifting the weight of the excavator. Lift the excavator according to the procedure described below. Do not operate it in any other way, as this may cause the excavator to be out of balance.

Do not lift the excavator when there are operators on it.

Please carry out slowly the lifting operation to prevent the excavator from overturn. Keep all personnel away from the working area during lifting. Do not move the excavator over people's heads.

Safe transportation of excavator

Understand and comply with applicable safety regulations, vehicle codes and traffic regulations during transportation. In order to choose the best route, it is necessary to consider the length, width, height and weight of the truck after loading the excavator. Do not start or stop suddenly or run at high speed during transportation. Otherwise, it will cause the loaded excavator to move or lose balance.

Precautions on maintenance:

Mark "Do not Operate It" warning message: Serious injury may occur if an unauthorized person starts the engine or touches control lever while inspecting or maintaining the excavator. Before maintenance, turn off the engine, remove the key and carry it with you. Mark a "Do not Operate It" warning message in a conspicuous place where a starting switch or control lever is mounted.

Regular inspection and maintenance

In order to have a good performance, the regular inspection and maintenance should be carried out in the use of the process, according to the nature of the work.

The following figure shows simple daily maintenance:

Regular inspection and maintenance list for Excavator														After that
Serial number	Time		Calculator display time											
	Project		50	100	150	200	250	300	350	400	450	500	550	
1	Working device	Butter												Every day,
2	Fuel	Drainage	①	①	①	①	①	①	①	①	①	①	①	Every 50 hours
3	Oil	Replace	①			①				①				Every 250 hours
4	Engine oil filter	Replace	①			①				①				Every 250 hours
5	Diesel filter	Replace	①			①				①				Every 300 hours
6	Air filter	Replace	①				①						①	Every 300 hours
7	Hydraulic oil	Replace										①		Every 800 hours
8	Hydraulic oil filter	Replace										①		Every 500 hours
9	Line	Check												Every 1,000 hours
10	Antifreeze	Replace												Every 1 year
Remark	1: Clean the air filter according to the working environment, at least once every 50 hours.													
	2: Add the antifreeze timely after it is reduced.													
	3: If the excavator is not used for a long time, please remove the negative electrode of the battery to prevent the battery from losing power.													
	4: If the work is done with a crushing hammer, the maintenance period should be reduced half.													
	5: The excavator maintenance accessories shall adopt the genuine quality original maintenance filter element.													

Notes: See the next page for more details.

Regular inspection and maintenance

Note: According to the different working environment, the air filter for the engine should be cleaned and replaced in time. In order to ensure that the engine can be operated under a normal condition, if the excavator is operated in a dusty environment, clean the air filter element every 10 to 20 hours.

The regular hydraulic oil should be used at the time of replacement of hydraulic oil (46# in summer and 68# in winter). If there are impurities in hydraulic oil, the high speed operation of hydraulic system will cause damage to hydraulic components.

Thank you for your trust and support to our company. If you have any questions during use, you can contact our company's sales or after-sales personnel.

All the staff wish you success in your work.

TYPHON Machinery

2642 River Ave #A. Rosemead CA 91770 United States.

typhonmachinery.com